

Hydraulic Dock Leveller with Hinge Lip • Model: G 8000

Hinge Lip 400 mm

- NB Nominal width
- NL Nominal length
- K Hinge lip extended
- KB Tapered lip
- L Total length
- O Service range up
- U Service range down
- H Closed height

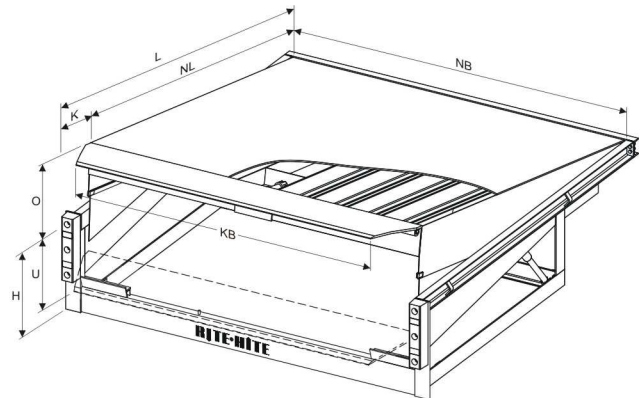

NL (mm)	K (mm)	L (mm)	O (mm)	U (mm)	H (mm)
2000	400	2400	400	350	600
2500	400	2900	400	350	600
3000	400	3400	400	350	600
3500	400	3900	530	375	700
4000	400	4400	530	375	700
4500	400	4900	530	375	700
Capacity 60kN Standard					

NB (mm)	KB* (mm)	Tapered Lip (mm)
1750	1750	Option
2000	2000	Option
2250	2000	2/125/330
KB* applies for all nominal lengths (NL)		

Standard Features:

- CE certificated
- Compliant with EN 1398
- Anti-slip deck plate, tread plate
- U-channel hang-in frame
- Hydraulic emergency stop
- Automatic height adjustment
- Dock control, 400/230V, 24V secondary voltage
- Automatic stop after power failure or emergency stop
- Power cables adjusted to pit size
- Steel construction painted RAL 7016
- Yellow/black safety warning stripes

Options:

- Dock control with automatic return
- Curb angle hang-in frame
- Flat steel hang-in frame
- Tapered lip for NB<2000 mm
- Dock box
- RAL colour of choice
- Zinc-plated finish
- Weatherseals
- Foam insulation
- Abrasive ramp surface
- Hinge Lip 500 mm
- Bio hydraulic oil and low temperature oil
- Dock bumpers in various designs

Other options available on request

Specifications subject to change without notice.

Project-related information: